

Vertu Realities Presents



2023 BioZone Project

Introduction

My name is Dr. Dennis J. Morris, MD and I am presenting the BioZone Project for funding consideration of my research and development project. The BioZone Project intends to deliver an integrated Biosystem platform capable of mitigating Biodefense, Healthcare, and Ecological concerns of an urgent nature. In regard to Biodefense, it is imperative that immediate action must be taken to counter natural and or intentional biological threats, reduce the risks thereof, and prepare for forthcoming pandemics. In doing so, the BioZone Project includes the introduction of new generation component Healthcare technologies that integrate seamlessly to provide the BioZone System. I chose the 'BioZone' title with regard to (Bio) meaning 'life' and (Zone) pertaining to a specific place on the planet, whether spatial or geographical, elemental (land, water, fire, air, and space), and or catalytic wherein our 'life actions' bring about specific reactions in a measurable sense to our planet.

The BioZone Project spans nearly a decade of personal innovation work that I call my 'Principius Medicus', a homage to Sir Isaac Newton's Principia Mathematica. Having always been inspired by the great minds' perseverance in their quests, and while working toward completing the fourth quarter of a forty-year career in Emergency Medicine and Trauma, I methodically attended my innate passion to innovate and developed my personal work, eager to discover where the process of innovation might lead me. Now, I too, have been able to cultivate a comprehensive and cohesive body of knowledge that holds the potential to significantly advance various fields of study and application while protecting the public and wildlife wellbeing.

In order to apply my body of work in a recognizable standard, social structure, and capital expense documentation, I chartered my company, 'Vertu Realities LLC' and modeled a clear framework for decision-making and accountability, one day hoping to provide an avenue for raising capital and managing resources to help ensure success and sustainability of the BioZone Project over the long term. I used 'Vertu' as the Old World descriptive of the word 'Virtue' of which I define as 'An application of servitude toward mankind in such a manner to be recognized by one's peers as morally righteous and good'.

In developing the BioZone System as a whole, I recognized the coordinated complement of my technologies relied on functional interoperability, and therefore the end result was to be only as efficient as to any of the individual components, a sort of weakest chain in the link analogy. Having been said, in Part One of the document I will discuss the foundation for the BioZone System first and then incrementally introduce the innovative technologies planned for forthcoming phases of the project. In Part Two of this document, I will break the project down into the integral expectations and refer to associate documents to provide lengthier technical discussions.

Background of the BioZone Initiative

Briefly, throughout my career in medicine I recognized that many conventional practices and procedures could be improved upon and in the last decade I started a project portfolio with my personal concepts and designs. I started with my solution to a two-century old design flaw wherein surgical instruments need to have an ambidextrous locking mechanism yet to date still

only provide a right-hand biased design (see Fig. 1). Subsequently I went down my design list developing and provisionally petitioning personal Intellectual Properties to protect my company property ownership. After amassing nearly 100 IP projects in my innovation portfolio, it wasn't until my experience as a frontline provider during the Covid-19 pandemic, that I realized the common denominator of my work was to develop the Emergency and Critical Care Unit of the future. At least half of my work immediately and seamlessly integrated into the common project I named the BioZone Unit.

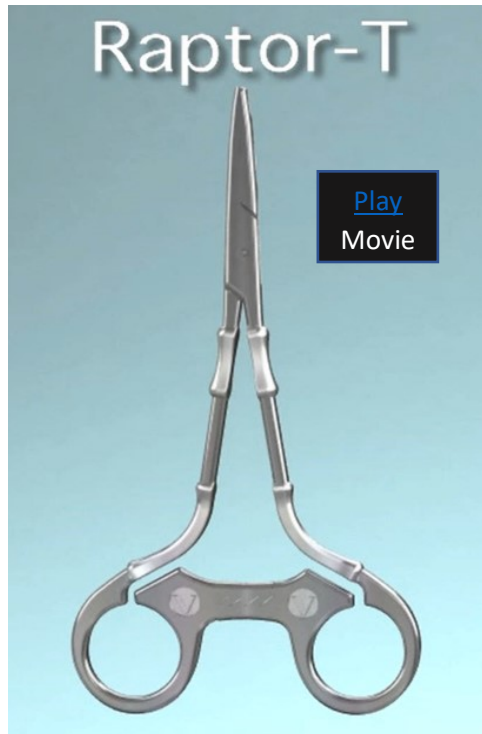

Next, after experiencing firsthand, the lack of preparation the Healthcare Industry, and the entire world for that matter, had in responding to life threatening biocontagions such as the SARS 2 Covid-19 virus, did I realize the full potential of the BioZone Unit as providing the World's first truly integrated Early Warning Prepandemic Biodefense Mechanism and means to ensure the healthcare and wellbeing of our children for the future as well as the same for our environment and wildlife.

Fig. 1 The BioZone Raptor Ambidextrous Surgical Instrument Technologies (Note: To play movie click on play box then press Ctrl + Click)

We had been lucky in the past 2 decades having experienced other novel lethal global viruses that fortunately did not acquire the transmission capabilities as did Covid-19. Yet now, we realize that in the next 3 years several thousand laboratories around the globe (many with bad actors) will be capable of gain of function viral manipulation as well as the ability to combine two or more pathogens into a super virus that can better spread to humans. The next pandemic is inevitable, forthcoming, and is predicted to occur in as little as 2 to 3 years from now.

So, the urgency to better prepare for the next pandemic is full throttle so reports such as the 2022 United States Biodefense Strategy and Implementation Plan or the 2022 Geneva Plan to combat future biocontagions are being disseminated throughout the scientific communities. What is most relevant, is the fact that after scrutinizing the data and information provided, the world simply does not have the detection means, early warning capabilities, Prepandemic preparedness, nor interventional capacity to do much more than that of which was done with the Covid-19 virus. Imagine the consequences if the next natural or manipulated contagion has a 40% or higher mortality rate instead of the 1.4% Covid-19 had. Imagine the devastation to the global economies and inconceivable loss of life.

In this regard, I am presenting my comprehensive BioZone Initiative and BioZone Project to provide a physician's perspectives and analysis of what can be done and what has to be done in the near future to provide countermeasures and mitigants to combat the next pandemic. I pray that through the next generation of innovative technologies that I have so diligently developed over the past decade that my work will serve the purpose to reduce pain and suffering and loss of human and precious animal life.

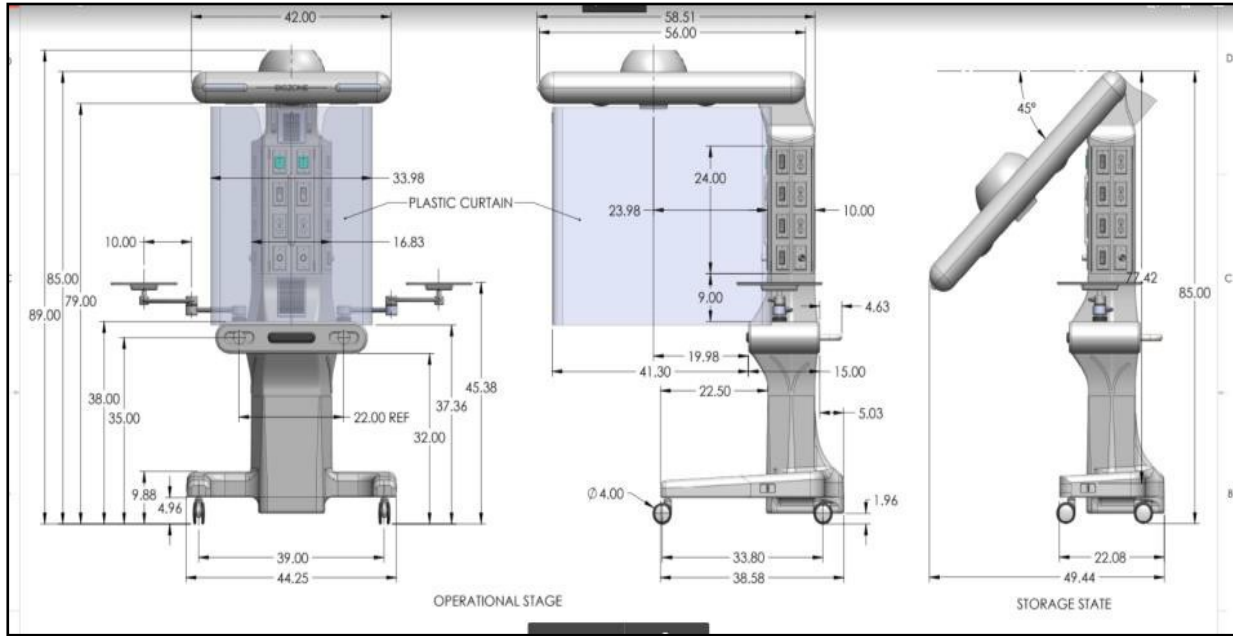

Fig. 2 The BioZone Base Unit

The BioZone Base Unit

First, I designed and petitioned the BioZone Base Unit (Fig. 2) to be a modular rapid assembly standalone apparatus serving a multitude of utilities while providing the centerpiece for the gamut of integrated technologies I had developed. To begin with, I analyzed what dimensions would best serve the intended functions of the BioZone System in regard to Healthcare facility doors, elevators, treatment room and stretcher dimensions, as well as patient comfort. I needed a sturdy means to house the unit subsystems as well as providing a novel proprietary isolation enclosure means. We, as Healthcare providers, simply cannot endure combatting the next serious contagion as we were mandated to do with Covid-19. In this report, it will become evident that the BioZone Unit will ensure that we won't have to.

I designed the BioZone Unit utility to be compatible with every imaginable patient presentation I could think of. The Unit had to be mobile, lightweight, autonomous, provide compatibility with items such as surgical tables and even able to serve as an obstetrical delivery apparatus for patients having potentially serious contagious presentations. I also designed the BioZone Unit capable of transporting a patient from one area of the treatment facility to another preventing contamination and exposure of pathogens by other persons. The overall dimensions and provisions of the BioZone Unit had to allow a patient to be comfortably contained within the enclosure means for the entire ER or hospital stay.

Next, I designed and petitioned a novel BioZone PPE garment that a contagious patient wears providing a sealable means to the upper torso or neck area of the patient with a loose-fitting gown component that functionally seals to the bottom of the unit enclosure drape. When the patient PPE gown is applied and sealed to the lower enclosure drape, an air sealed quadrilateral cubical enclosure is provided serving as the BioZone isolation compartment. I designed the upper portion of the BioZone base unit to incline or decline wherein a mechanized 45-degree

skyward incline of the upper section of the unit lifts the patient garment off of the patient's body. In this manner, the patient's body is completely exposed to the healthcare providers and conventional 'direct patient care' may be provided while the respiratory elements of the patient are isolated from exposing the treatment zone and provider staff. Reversely, the same mechanism serves as a reverse isolator means for immunocompromised patients receiving chemotherapy for example. The unique design of the BioZone patient PPE even permits rotation and proning of the patient in the case of prolonged intubation and ventilator assistance is needed.

Next, I designed the BioZone inner isolation chamber to have atmosphere conditioning, sealed access to the head and neck area in the case the patient had EENT complaints or injuries or needed to be intubated, have a translatable communication means, have specific auditory and visual stimuli for applications of the BioZone System and or entertainment and capabilities of consuming food. I designed the enclosure drape to be durable yet clear and in a NASA BioZone version, I even configured the drape material out of radiation resistant materials.

The overall design of the BioZone Base Unit needed to be easily assembled and disassembled, durable for shipping anywhere on land, air, sea, or space, lightweight, and able to serve as a standalone comprehensive all-in-one Emergency and Critical Care Station. Also, it needed the novel isolation enclosure to mitigate the need for healthcare providers and staff to don and doff PPE the entire shift which cost the Healthcare Industry billions in dollars in throw away expenses as well as piles and piles of medical waste.

To develop the minimal viable product (MVP) version of the BioZone Base Unit I contacted product realization companies and had Rough Order of Magnitude (ROM) estimates prepared which topped one million dollars. With these kind of cost considerations being prohibitive for me, I turned to the University of Texas at Austin Engineering Department and sponsored a senior student design project. We had the most interest in all of the submitted projects and attracted the four top graduating seniors of the class who prepared a comprehensive design and project report (Attachment). The requirements had to provide a N Class negative pressure means for the BioZone Unit that would pass regulatory requirements. Concurrently, I had renderings prepared by the R2FACT Company of Kansas City, Missouri and the following pictures are renderings of the basic BioZone Unit design.



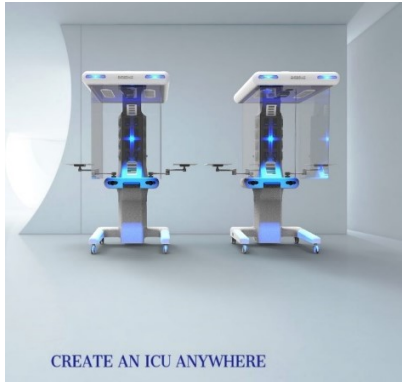

Note that the arrays of the novel BioZone medical devices designed to situate on the lateral aspects of the vertical body work station section are not shown. The attaching patient garment that provides the inferior aspect of the enclosable cubic enclosure chamber is also not shown.

So with the BioZone Base Unit designed, the next phase of my work was to integrate my decade of advanced medical technologies and innovations I had been working on relative to improving Emergency and Critical Care Medicine with that which is needed to provide the BioZone System the ability to address and mitigate the Biosecurity and Biodefense requisites delineated in the 2022 US Biodefense report. The following sections will briefly refer to more than forty novel technologies cooperatively coordinated into the BioZone System and applications thereof. An additional BioZone technical document that describes the BioZone proprietary technologies in detail is attached (see Attachment).

The BioZone Unit Versions

In order to address our National Biosecurity necessities, the BioZone System needed three primary versions of the BioZone Unit each specifically designed for and deployable to ‘Point of Care’ (POC) treatment facilities, areas of high public congregation, and an outdoor free range application. All three versions have data acquisition means, detection and analysis means, data transmission, and network communication provisions. The three units as a system comprise a ‘One Health’ coordinated means integrating public health with the environment and wildlife in regard to data acquisition applicable to a Biodefense Countermeasure and Mitigation Program. The three versions are capable of detecting known and unknown pathogens, VOCs, toxic gases, chemical agents, and radiation. Additionally, conventional provisions such as air quality monitoring is provided.

1. The Healthcare ‘Point of Care Version’ (POC)

The POC BioZone version as depicted in the renderings is specifically designed for widespread deployment to healthcare facilities of any kind. The completely mobile and space saving design provides a comprehensive standalone ‘all-in-one’ Emergency and Critical Care apparatus with functional interoperability of its component technologies, deployable anywhere on land, sea, air, or space. The innovation by itself will provide public healthcare system a solution for mobile intensive care medicine stations in the time of crisis capable of deployment in dangerous engagement zones and to underserved populations anywhere on the globe. The necessity for Pop Up Hospitals will be mitigated. Additionally, the POC version is designed to become a standard treatment station applicable to all Emergency Departments and Intensive Care Units.

2. The BioZone Roaming Unit Version (RV)

The roaming version of the BioZone Unit is a design variation of the BioZone POC Unit and is intended for utilization in zones of high public congregation such as malls, sports arenas, large ball rooms, corridors, airports, courthouses, or civic centers, for example. This version is designed for stationary deployment and or autonomous traversing of the facilities with a

programmable navigation system. In this aspect, a deployed roaming unit will seek out specific identifiable pathogenic elements, VOCs, toxic gases and chemicals, and alert to previously unencountered specimens.

3. The BioZone Field Unit Version (FV)

The field version of the BioZone Unit is a different design variation intended for outdoor free range deployment therein providing the environmental and wildlife aspects of the BioZone Biodefense System. The BioZone FV is equipped with BioZone System component devices designed for a range of applications such as known and unknown pathogen element, VOCs, toxic gases and chemicals, and even prion detection from the air which is a significant and relevant breakthrough in mitigating prion diseases such as Chronic Wasting Disease in cervids.

The BioZone Novel Innovation Components

The complement array of technologies and novel devices integrated into the BioZone System and units are included in the referenced attached BioZone System technical document. Over Forty component innovations are integrated to comprise a next generation Biodefense and Critical Care diagnostic, management and interventional standalone treatment apparatus. One example component of the novel technologies and devices is the BioZone Multipurpose Biosensor which is a key component of the overall BioZone Biodefense provision.

The BioZone Multipurpose Biosensor

With Healthcare facility exposure to Covid-19 and the numerous manifestations and adverse sequelae encountered during the pandemic, the BioZone System needed a device capable of detecting specific pathogens rapidly and accurately. In doing so, a contagious patient would be able to be assessed in an anteroom type triage zone and if being detected to have a known or previously unencountered contagion requiring isolation, the patient may then be immediately isolated from the treatment zone, staff, additional patients, and provider staff within the confines of the BioZone enclosure chamber.

In order to provide such a means for rapid pathogen detection and analysis, I developed a novel specialized BioZone Face Mask Respirator capable of more efficiently capturing pathogen elements and volatile organic compounds (VOCs) whereby the samples are subjectable to rapid POC analysis. The technology for the BioZone face mask as well as for the BioZone Multipurpose Biosensor is described in a separate technical document attached (see Attachment). Succinctly, I modified existing technologies into a cooperative integrated biosensor comprising an improved quartz crystal microbalance system with an improved macrobubble biosensor with an improved electronic nose wherein the end result provides a significantly enhanced means of pathogen and VOC detection with a much greater sensitivity and specificity as compared to conventional art. The BioZone Multipurpose Biosensor was next expanded to detect pathogens and VOCs in the ambient air environment inclusive of Prions such as that causing Chronic Wasting Disease (CWD) in cervids. Incidentally, both the CDC and WHO as of March 2023

cannot refute CWD as potentially becoming transmissible to humans in the next several years and the disease is 100% fatal.

I incorporated the BioZone Biosensor into the integral BioZone Unit and am able to provide rapid detection and analysis immediately at the Point of Care (POC), zones of public congregation, and in the free range wildlife habitat which is a novel application for a National Biodefense strategy and is a significant advantage over present day procedures.

II. Part Two

Executive Summary

The BioZone System will provide solutions for preventing, detecting, forecasting, and treating contagious diseases that have the potential to cause significant health, economic, and social burdens and potentially lead to the next pandemic. The BioZone System, as a whole, provides an independent ecosystem, in a broader sense, of innovative solutions collectively addressing and mitigating the multitude of current day Biosecurity and Biodefense concerns as described in the 2022 United States Biodefense Strategy and Implementation Plan. The BioZone Project is therein a rise to the call response platform designed to help secure the safety and wellbeing of the United States from Bioterrorism, naturally or manipulated Biocontagions, and provide an Early Warning System and Prepandemic Preparedness Program. Additionally, the BioZone System provides a multitude of next generation Healthcare technologies and innovations significantly improving current art. There are currently no rapid deployment and ready-made solutions that offer the BioZone's capabilities. Current methods are custom made either at medical facilities or on-site with varying degrees of effectiveness and much higher costs than BioZone's pre-configured solutions.

The BioZone System will consist of cooperatively interfaced BioZone Unit versions comprising in one aspect a BioZone Field Station. This specialized field unit will utilize the proprietary multipurpose biosensors to detect and monitor the presence of infectious agents among wildlife in the free-range environment. A means for addressing zoonotic transmission is finally provided. Furthermore, the project aims to provide novel methods for detecting and treating prion diseases in free range cervids showing no signs of CWD.

A BioZone Point of Care (POC) Healthcare Unit will also utilize a novel sample collection means and the BioZone Multipurpose Biosensors to detect 'known or unknown' biocontagion agents and or Volatile Organic Compounds (VOCs) in a patients' exhaled air with superior sensitivity and specificity.

The mobile Roaming BioZone version utilizes the BioZone Multipurpose Biosensors to detect biocontagion agents and other hazardous substances in areas of congregation such as sports arenas, airports, schools, malls, and conference halls, to name a few examples.

The BioZone Project will develop an integrated BioZone Network Early Detection, Activation Response, and Management Protocol that allow for autonomous and continuous transmission of data between the various BioZone Units and monitoring agencies. Additionally, as mentioned, the project includes the development of a multitude of advanced medical technologies for the

BioZone Unit comprising a superior mobile and rapidly deployable ‘All-in-One’ Emergency and Critical Care Apparatus anywhere on land, sea, air, space, or high-risk areas such as battlefields.

If successful, the BioZone Project will have a highly significant impact on public health, environmental conservation, and national security. The project provides the potential to improve the health and well-being of wildlife and game, protect natural habitats and ecosystems, and reduce the risk of zoonotic disease transmission to humans. It could also promote and protect local and national recreational revenues and significantly reduce healthcare expenditures by billions of dollars while potentially saving millions of lives. Additionally, the project's impact will extend to military personnel and combat zones, providing a valuable asset for protecting our military personnel and civilians from infectious biocontagions and bioterrorism threats. Overall, the BioZone Project represents a remarkable innovation with broad applicability across multiple claimed industries.

The component elements of the BioZone Project are cooperatively interfaced to comprise the BioZone System. The BioZone Project and System collectively comprise a comprehensive Biodefense Plan aimed to protect society and wildlife from the inevitable forthcoming dangers of zoonotic disease transmissions, accidental or intentional introduction of novel and potentially life threatening Biocontagion interactions, and or the deadly and rapidly spreading infectious protein (Prion) diseases now devastating our wildlife populations. Any one or combination of these Biocontagions has the potential to be the cause of the next pandemic.

Additionally, forthcoming BioZone Project provisions comprise novel means and methodology to clear harmful pollutants such as PFAs and Volatile Organic Compounds (VOCs) from the cohabitant environment. The BioZone Project intends to:

- Develop and deploy BioZone Field Stations in wildlife habitats across the United States, which will utilize proprietary Biosensors to detect and monitor the presence of infectious agents among wildlife in the free-range environment.
- Develop proprietary alimentary supplements for specific wildlife that will positively modify their gut microbiome, enhance their immune system, prevent the absorption of prion proteins across the intestinal mucosa, dissuade the abnormal folding of prion proteins, and persuade the refolding of prion proteins to a noninfectious normal configuration.
- Develop BioZone POC Healthcare Units (HCUs) that utilize a novel BioZone Multipurpose Biosensor to detect biocontagion agents in patients' exhaled air and provide a novel and improved isolation enclosure for contagious presentations permitting direct patient access and conventional care, as well as a decontamination and sterilization means for healthcare facilities. No other isolation enclosure has this direct care ability.
- Develop mobile Roaming BioZone Units that also utilize the BioZone Multipurpose Biosensors to detect biocontagion agents and or other hazardous substances in areas of congregation such as airports, churches, schools, malls, or sports arenas, for example.
- Develop and provide integrated BioZone Network Early Detection, Activation Response, and Management protocols wherein the autonomous and continuous transmitted data information is shared between the various BioZone Units and local, regional, and national monitoring agencies.
- Develop and provide advanced medical technologies for the BioZone HCUs that significantly improve upon conventional devices.

- Develop and provide a mobile, rapidly deployable comprehensive All-in-One Emergency and Critical Apparatus for times of need and for high-risk areas or underserved areas of the planet.

The proposed BioZone Project therefore has the potential to impact several areas, including the environment, wildlife and game, local and national recreational revenues, public health, and healthcare personnel and providers. If successful, the project could significantly improve the health and well-being of wildlife and game by reducing the spread of infectious agents, protecting natural habitats and ecosystems, and providing novel more effective treatments. It could also promote and protect local and national recreational revenues by improving the overall health of wildlife populations and reducing the risk of zoonotic disease transmission to humans. Additionally, the project could reduce healthcare expenditures by billions of dollars by providing a comprehensive biodefense plan capable of saving millions of lives.

The project's impact extends to military personnel and combat zones, wherein the mobile and rapidly deployable BioZone Emergency and Critical Apparatus may provide a valuable asset for protecting military personnel and civilians from infectious biocontagions and bioterrorism threats as well as providing an immediate lifesaving critical care station anywhere on land, sea, air, or space. Overall, the success of the BioZone Project aims to have a significant impact on public health, environmental conservation, and national security.

Proposed Work

To provide the multifaceted comprehensive biodefense plan to protect the environment, wildlife, and human health from the emergence and spread of infectious agents, the project has three primary components: the BioZone Field Unit, the BioZone Mobile Roaming Unit, and the BioZone Point of Care (POC) Healthcare Unit. The BioZone Field Unit uses novel approaches and technologies to surveil and monitor wildlife habitats for contagious agents and elements and provide nutrition supplements to improve the immune system and prevent wildlife disease manifestations. The BioZone Mobile Roaming Unit provides a detection and analysis means for known and unknown contagions, VOCs, and other hazardous elements. The BioZone Healthcare Unit provides an innovative approach to POC facilities for patient care, pathogen detection and analysis, and mitigation to intervene in healthcare facility acquired infections.

The BioZone Initiative and Project's overarching goal is to additionally provide a modeling construct that offers a foundation for incorporating forthcoming newly derived associate technologies into the system. In this way, continuous improvement will impact the overall success of the BioZone System. A modular configuration of the component BioZone technologies is preferred, which is cost-saving, compact, completely mobile, lightweight, and deployable anywhere on land, sea, air, or space. It will be demonstrated that these advantages of the BioZone Units will be significantly advantageous by providing rapid deployment capabilities in high-risk areas or underserved areas. This project offers an innovative and comprehensive solution that addresses healthcare challenges and concerns, making it an invaluable asset for any organization seeking to improve global health outcomes.

The BioZone Project modular and adaptable designs and configurations allowed for a seamless and easily customizable platform capable of addressing a diverse range of project objectives. For

instance, the initial Covid-19 scope of the BioZone System was further expanded to address the environmental, wildlife, and ecological aspects of the National Biodefense Strategy. The Point of Care (POC) integrated HCU was also developed and subsequently modified to provide solutions to a number of healthcare problems. Moreover, a BioZone Space Version was developed, addressing issues such as spacecraft impacts and high-energy cosmic radiation exposure.

As a complex matrix of advanced component technologies, the BioZone Project and System must be evaluated as a whole. It provides high-value solutions to numerous requests disseminated from governmental agencies. For example, the BioZone Project and System is a response to the 2022 National Biodefense Strategy & Implementation Plan, which calls for countering biological threats, enhancing pandemic preparedness, and achieving global health security. This framework organizes how the U.S. Government manages its activities to assess, prevent, prepare for, respond to, and recover from biological threats more effectively. Additionally, it builds on a holistic 'One Health' approach that recognizes the interconnections among people, animals (domestic and wildlife), plants, and the environment. In this way, the One Health approach interweaves the efforts needed to address the threats to all of these realms.

The BioZone Project also provides innovative solutions to local and state requests for addressing and preventing the spread of specific disease presentations. Currently, several wildlife populations, public recreational revenue, and human beings are endangered by such diseases with a potential for spillover zoonotic transmission. The BioZone Project aims to address these concerns with novel solutions that prevent and mitigate the spread of these diseases, thereby improving the health outcomes of both wildlife and human populations.

The National Biodefense Plan's strategy expands efforts to address the full range of future biological threats, including those of natural, accidental, and deliberate origin. It also incorporates both technological and policy needs revealed by the Covid-19 pandemic and provides an opportunity to build core values of equity and accountability into our efforts to protect the health and security of the American people. The project plan's success relies on a culture of collaboration and experimentation to address novel and persistent threats in a way that ends rather than exacerbates existing inequities.

The BioZone Innovation & Project recognizes the complexity of the problems and the need for a comprehensive and multifaceted approach to solve them. I believe that the BioZone Project and System has developed the mechanisms necessary for successful intervention. My intention is to provide a comprehensive set of strategic provisions, including novel technologies, countermeasures, and mitigants necessary to achieve the goals of the National Biodefense Strategy & Implementation Plan.

In general, the proposed work will provide the United States with a paradigm-shifting approach to integrating environmental, wildlife, ecological, and public health wellbeing. Using autonomous BioZone Field Units, an Early Warning Biodefense System is delivered, capable of detecting and analyzing known and unknown harmful pathogens, contagions, and other biohazards. The Field Units also provide a means for decontamination and sterilization of a specific BioZone Area radially peripheral to the Field Units, as well as a preventative means to isolate and prevent the spread of biocontagions. The acquired data is remotely transmitted to autonomous Central Control Stations for further dissemination. Additionally, the Field Units provide novel identification and tracking of infection-transmitting vectors before they become physically detectable, enabling early therapeutic intervention and treatment.

In another general aspect, the proposed work provides a Point of Care (POC) Healthcare Facility Early Warning Biodefense Mechanism. The system detects known and unknown contagious pathogens, analyzes and compares them to pathogen libraries through machine learning and AI-assisted software, and rapidly and adequately isolates patients from the public, staff, and healthcare professionals to prevent further transmission of the Biocontagion. The POC BioZone Unit decontaminates and sterilizes the Bio-Zone Area radially peripheral to the unit, provides a proprietary temporary isolation cabinet enclosure, and provides a safe transport means for the isolated patient to be brought to other areas of the facility for conventional treatment and necessary interventional care. The BioZone POC Unit temporarily and comfortably houses the patient for as long as they remain a contagious threat to the public and staff and are discharged pursuant to protocol requirements and mandates.

Moreover, the expanded scope and modular construct of the Healthcare BioZone Unit intends to provide a novel Pulmonary Drug Delivery System. This system can facilitate enhanced therapeutic delivery to pulmonary tissues, activate pharmaceutical drug carriers and modulators, mitigate regenerative and reparative pulmonary damage, prevent cytokine storm development, and offer novel treatment modalities for a vast number of inflammatory diseases. The remarkable versatility and efficacy of the Healthcare BioZone Unit's modular design make it an invaluable tool in improving global health outcomes and promoting public health and wellbeing.

In addition to the advanced technologies discussed above, the BioZone System comprises a novel standalone all-in-one Emergency and Critical Care Apparatus that is mobile, lightweight, and compact, allowing for easy transport to any area on land, sea, air, or space. The apparatus will include improved airway management, an EKG with improved interpretive signal detection and analysis, and an improved vital sign determination means. Additionally, it offers more accurate oxygen saturation determinations, an increased survival rate means for patients having undergone cardiac resuscitation, and the ability to detect acute cardiac events and developments prior to conventional equipment. The system also offers a means to better identify subtle ischemic events in patients, such as Van Negative Cerebral Hypoxic Events, and significantly reduce the time that healthcare providers document, enabling more direct patient care time availability. The BioZone System also features an innovation blockchain application network and participation means, as well as countermeasures and mitigants to surveil environmental and wildlife issues such as Prion diseases like CWD of deer and elk. The system is also proprietarily designed to remove chemical pollutants like PFAs from land and water that affect fish, wildlife, and human health and wellbeing.

In summary, the Vertu Realities BioZone Project proposes to provide an early warning biodefense system, an all-in-one emergency medicine and critical care evaluation and treatment apparatus, improved and safer means for healthcare providers to evaluate, manage, and treat serious contagious disease patient presentations, novel therapeutic treatment modalities, significant advances in medical device technologies, and a wildlife and environmental conservation program and platform. The initiative can save billions of dollars in United States healthcare expenditures and has the technological capacities to save millions of lives.

The BioZone Project additionally introduces a novel 'non-lethal' hunting practice of animals, providing vital project data, animal tracking provisions, testing of the animal for identifiable diseases, recreational opportunities for the public, and a broad spread means for clearing toxins and pollutants from our land and water systems. The BioZone Initiative and Project represents a

comprehensive and innovative solution to address the multifaceted and complex challenges of preventing, detecting, forecasting, and treating the emergence and spread of infectious diseases, promoting public health and wellbeing, and preserving environmental and wildlife health.

The current procedure:

The limitations of current biodefense approaches include inadequate surveillance and monitoring means in the POC, areas of group congregation, and in the free range. There is a lack of early detection and analysis capabilities, and limited treatment options in the field.

Currently, there is no comprehensive system or approach in place to address biodefense in an interconnected ‘One Health’ way. The lack of a coordinated approach and system leads to limitations in the ability to detect and respond to emerging infectious disease threats in a timely and effective manner, which can result in significant health, economic, and social burdens. Additionally, there are limitations in our ability to manage and maintain the health of wildlife populations, which can also impact public health and the environment. Finally, healthcare facilities rely on traditional methods of isolation, decontamination, and sterilization, which can be time-consuming and potentially harmful to patients and healthcare personnel.

For detecting and managing wildlife diseases, such as Chronic Wasting Disease (CWD), the current procedure involves culling and testing of wildlife specimens in certified laboratories. For CWD, hunters are asked to voluntarily shoot animals showing signs of the disease and bring at least the head to a testing facility. However, this method is not foolproof and there is no adequate system for autonomous surveillance, monitoring, tracking, and isolation of undomesticated wildlife carrying potentially serious contagious and transmittable diseases. Considering a hunting ranch with but a single detected deer with CWD causes the ranch to be quarantined, therein halting the ability to generate revenue on the premises and dropping the land value by 80%, it is no surprise that ranchers are reluctant to participate with the current CWD detection process. The BioZone Field Unit managed by the Wildlife and Fisheries personnel will mitigate this problem.

There are also no known curative treatments or vaccines for Prion Diseases, such as CWD, and the neurodegenerative consequences are 100% fatal. Additionally, there is a risk of zoonotic transmission, as evidenced by past cases of Prion Diseases known to have spread to humans through the consumption of infected meat and or funerary cannibalism.

It is imperative that technology is developed to detect contagious pathogens in wildlife before they show symptoms of disease and to prevent the absorption of prions across gut membranes and the blood-brain barrier. It is also crucial to integrate detection and data with local, regional, and national agencies to activate procedural intervention and alert healthcare providers to the vicinity of environmental disease detection and recent travel exposure to environmental disease.

The current procedures and limitations in healthcare facilities regarding pathogen detection, isolation, and treatment present a significant risk in the event of a future epidemic or pandemic. The lack of an autonomous means for detecting specific pathogens and integrating them with an Early Warning Biodefense System notification system leaves healthcare facilities unprepared for the next outbreak. In addition, the need for mandated PPE and the delays it creates in critical care interventions and patient care, as well as the cost and error-prone nature of Covid testing, all contribute to a healthcare system that is ill-equipped to handle a pandemic.

The Covid-19 pandemic exposed the shortcomings of healthcare facilities, with providers themselves dying due to workplace exposure and inadequate protection. The financial pressures faced by hospitals, with profitability ratios of 1-2% of total revenue, mean that most hospitals are unable to retrofit treatment rooms and treatment zones, leaving them vulnerable to future outbreaks. The BioZone HCU mitigates this problem.

Alternative technologies are essential to prevent and manage the next pandemic, which is only a matter of time before being encountered. The development of autonomous pathogen detection systems and integration with an Early Warning Biodefense System, as well as the implementation of rapid isolation means and non-invasive patient evaluation and management systems, are crucial in preventing future pandemics from once again overwhelming healthcare facilities and leading to catastrophic outcomes that may be far worse than that of Covid-19.

Innovative Approach

The BioZone Project is innovative in several ways:

- The BioZone Project integrates multiple technologies to create a comprehensive biodefense plan that addresses the spread of infectious agents in wildlife and humans.
- BioZone's approach creates the same conditions of full sizes negative pressure ICU or contagious disease rooms in approximately the same size as the upper half of a hospital bed. No other apparatus offers this level of ICU capability in so small a form factor at such a low cost with easy deployment anywhere.
- The use of integrated novel Multipurpose Biosensors and proprietary food supplements to alter the gut microbiome in wildlife is unique and innovative.
- The development of a Healthcare point of care BioZone Unit (HCU) that continuously and autonomously scans the facilities for detectable identified and unidentified Biocontagion agents and elements is also novel.
- The BioZone Project also proposes a novel approach to patient isolation permitting direct patient care without the need for PPE.
- The project's Phase Two plan aims to further develop a multitude of innovative technologies, including an enhanced physiological parameter signal detection and interpretation, novel means for treating near-zero gravity physiological manifestations, and pulmonary repair and cellular regeneration means, among others.
- Additionally, the BioZone Project's innovative approach provides a broad spread Prepandemic Preparedness that is innovative in its own right.
- The BioZone Project proposes a comprehensive and innovative approach to combat and treat infectious diseases that can cause significant health, economic, and social burdens. The project addresses prevention, surveillance, detection, monitoring, forecasting, mitigating technologies, and treatments through an interconnected system that merges environmental, ecological, and public health issues. The project takes a multifactorial approach, considering individual aspects that lead to pandemics and addressing them accordingly.
- By altering the gut microbiome of wildlife carrying potentially contagious prion diseases, the project aims to alter the immune system and prevent susceptibility to diseases such as CWD. Furthermore, the project proposes binding prion proteins with supplement agents, rendering them unabsorbable, or preventing their accumulation in the central nervous system and

subsequent neurodegenerative disease. By altering the gut microbiome of wildlife populations, the project can prevent devastating population losses and support hunting revenues for involved states. The BioZone Project's cause-and-effect relationship is an innovative approach to address the stated issues at hand, with an all-in-one solution platform that merges environmental, ecological, and public health issues.

- The BioZone Project's innovative approach also addresses the multifactorial components that lead to the emergence and spread of infectious diseases by providing the only comprehensive platform that integrates environmental, ecological, and public health issues into a single project system. One example of this approach is the prevention and detection of infectious diseases through the development of the BioZone Field Unit, which can be configured for any 'Bio-Zone' on the planet. The unit is equipped with a Biosensor device capable of detecting a predetermined catalog of infectious agents through an animal's saliva, excrements, and/or in the air vicinity of a respiring animal. This device can be disseminated to deer hunting properties and or leases across the nation, with a stipend agreement with the landowners mandating a 'No Hunting Zone' to be established within a predetermined radial periphery to the BioZone Field Unit.
- Additionally, the BioZone Project aims to address environmental issues such as the prevention and early detection of Prion disease and environmental PFAs, which are essential components in safeguarding the public against infectious diseases and preparing for the next pandemic.
- The Biosensor device will provide the capabilities for all mentioned detection routes and will be able to compare the detected biological agents with a Central Station library. In the case of an activated Biosensor, a marker substance would be dispersed onto the body of the animal, visible to a specific light wavelength spectrum such as infrared illumination. A nighttime drone deployment would then be able to detect the marked animal and track the travel coordinates. Alternatively, an activated Biosensor could cause a mechanized enclosure stall to close, preventing the 'infected' animal from leaving the premises. Biosensor activation would lead to software notification of participating field agents to apprehend the diseased animal and manage it according to protocols developed by local, regional, and national regulatory agencies. These approaches are also novel.
- The BioZone Project's Biosensor means would also be fashioned to detect prion proteins and isolate or track the animal before it can be hunted and potentially eaten as food consumption. In this case, the BioZone Unit and applications may potentially prevent transmission of prion proteins to humans through meat consumption. Overall, the BioZone Project's approach to prevention and detection of infectious diseases is innovative and incorporates multiple strategies to combat and treat the emergence and spread of infectious diseases.
- The BioZone Healthcare Unit (HCU) is a point of care facility provides a sensor array that continuously and autonomously scans for detectable Biocontagion agents and elements. One innovative approach with regard to the HCU is the use of a novel 'Multipurpose Sensor', wherein the patient presenting to a healthcare facility with a given predetermined scoring determination will be asked to submit an exhaled specimen that is captured in a proprietary face mask respirator rendering the respired air better capable of Biosensor detection of Biocontagion agents and elements. This innovative approach is designed to improve the accuracy and speed of detecting Biocontagion agents and elements in patients, reducing the time it takes to diagnose and treat infectious diseases. The HCU is also equipped with

machine learning and advanced AI software that can compare the detected biological agents with a Central Station library and detect previously unencountered agents or contagions.

- The BioZone HCU innovative approach also includes designing the HCU to serve as a ‘Standalone all-in-one Emergency and Critical Apparatus’ that is modular, easily and rapidly disassembled and reassembled to fit in a relatively small shipping crate, is lightweight, space conserving, and can be rapidly deployed anywhere on land, sea, air, or space. This is completely novel to the fields of Emergency Medicine and Critical Care.
- In addition to the Multipurpose Biosensor, the HCU is also equipped with a range of medical diagnostic tools, such as blood analyzers, imaging equipment, and POC lab-on-a-chip testing devices. This enables healthcare professionals to diagnose a range of illnesses and conditions and provide immediate treatment quickly and accurately.
- The BioZone Project believes that the HCU has the potential to revolutionize the way intensive healthcare is delivered, particularly in areas where access to medical facilities is limited. The HCU can be easily deployed to remote or underserved areas, providing access to high-quality advanced medical care to those who need it most. No such system exists to date.
- Overall, the BioZone Project is taking a multifaceted approach to disease prevention and management, with a focus on early detection, prevention, and treatment. By utilizing innovative technologies such as Biosensors, AI, and proprietary nutritional supplements, the BioZone Project is helping to safeguard public health and prepare the planet for future pandemics.
- The HCU also provides a harmless ‘Bio-Zone’ area decontamination and sterilization designed according to the specific Bio-Zone being treated, which can treat an entire waiting room versus a hallway or triage anteroom zone. It provides external and internal excimer lamps capable of rapidly and safely sterilizing and/or decontaminating the ambient atmosphere, equipment, and furniture. The HCU also has a HEPA filtration and UV sterilization means that serve as a redundant decontamination and sterilization means for the area, and the rapid excimer enclosure treatment provides rapid and safe patient turnover. This decontamination system means is novel.
- The BioZone HCU is designed to remediate numerous additional healthcare problems, beyond the scope of the document, and additional details of the entirety of the BioZone HCU are provided in attached documents.
- Phase two of the BioZone Unit development includes introducing several proprietary technologies, such as improved airway management equipment, enhanced physiological parameter signal detection and interpretation, remote transmission of signal determinations and real-time assessment capabilities, and more. Other innovations include novel means for identifying subtle Ischemic events in patients, a means for improving the survivability of patients having undergone CPR resuscitation, and a novel Pulmonary Drug Delivery System, among others. These technologies are all novel and superior to conventional means.

Key Technical Challenges:

The BioZone Project faces several key technical challenges, including the ability to provide an adequate National biodefense surveillance and monitoring means given the sheer geographical area needing to be surveilled and monitored. As per the 2022 US Biodefense report, “Infectious disease threats do not respect borders. Urbanization, climate change, habitat encroachment,

economic interdependence, and increased travel, coupled with weak health systems, increase the ability of infectious diseases to spread rapidly across the globe. Novel infectious diseases, the resurgence and spread of once geographically limited infectious diseases, zoonotic diseases, and antimicrobial resistance can overwhelm response capacities and make outbreaks harder to control". With this in mind, the POC BioZone Unit version is perhaps the easiest to disperse considering the specific interface zone between patients and healthcare providers is already delineated. The Healthcare Facility BioZone Unit distribution may correlate to predetermined population zones as governed by the CDC.

This is not the case with the roaming version and the free-range versions of the BioZone Units which essentially must be relied upon to surveil and monitor all other nonmedical bio-zones. Additionally, natural wildlife habitats encompass various terrain incumbrances and private property impasses. This is one reason to include prion disease detection in cervids in the broad scale surveillance and monitoring program considering the Wildlife and Fisheries agencies, for example, can mandate rotational placement of a free-range BioZone Biosensors to accurately detect CWD in cervids. Alternatively, the EPA could mandate air quality monitoring or the National Biodefense Plan could provide a similar mandate for national security reasons. The BioZone Project will need to partner with appropriate government agencies for regulatory hurdles and certifications.

The BioZone Nutritional component(s) is a technical challenge given the necessary research and development and subsequent regulatory hurdles and certifications. I will address these issues in a cooperative partnering with appropriate government agencies and conduct ongoing research with institutions, such as the Pennington Biomedical Research Facility in Baton Rouge, Louisiana, to establish the efficacy of the supplement objectives as outlined in previous sections. I anticipate subcontractor assistance in the development of the BioZone product line.

Another technical challenge is the development and integration of advanced technologies, such as the improved airway management equipment, enhanced physiological parameter signal detection and interpretation, and remote transmission of signal determinations and real-time assessment capabilities, among others, as outlined in the Phase two innovations. This will require significant research and development efforts and collaborations with institutions and industry experts to ensure the successful integration and implementation of these technologies into the BioZone system.

The final prototypes of the BioZone Field Stations and HCUs will require considerable financial input and I am seeking funding assistance accordingly. I have already successfully developed a proof-of-concept prototype meeting the negative pressure requirements, monitoring capability, and accessibility for treating ICU patients or wildlife. I need further funding to move from the prototype stage to a certified, approved, and fully tested medical or veterinarian ready apparatus.

The phase two advanced technologies planned for the HCU will require considerable research and development to realize the proposed utilities. Again, through research and development with World Renown product realization companies subcontractors such as the Plexus Organization in Wisconsin and Pivot International of Kansas City, Missouri, I feel I can achieve these objective technologies. Note I have written and submitted patent applications on the majority of key BioZone System technologies.

Overall, the BioZone Project presents several key technical challenges, but the innovative approach and collaboration with institutions, industry experts, and regulatory agencies provide a strong foundation for successfully addressing these challenges and implementing a comprehensive Biodefense system.

Technical challenges already addressed and solved:

- The negative pressure isolation concept and method has been tested and verified to achieve its objectives.
- Created working prototype
- Designed form factor and components for human use.

Technical challenges remaining

- Need to design form factor for wildlife use.
- AI air monitoring system, AI driven respiratory/air vaccine, medicine treatment system.
- Wildlife containment system.
- Quantitative Milestones and Objectives
- Conceptual and Systems layout
- Mechanical (enclosure, ventilation, ingress/egress, etc.)
- Electrical (power bus, monitoring sensors, data bus, motors, etc.)
- Form factor (coverings, frame, mobility systems, user interface, patient support)
- Sensor integration (data layer, UX, software development)
- AI engine development for real-time monitoring, assessment, and treatment
- Generate 3D models
- Develop circuitry
- Code UX and AI BioZone monitoring and treatment solution
- Alpha testing phase under controlled laboratory conditions
- Beta testing human BioZone under limited hospital
- Beta testing wildlife BioZone version in limited field conditions
- Adjust BioZone versions per beta test results
- Present BioZone for regulatory approval

Meaningful Impact

The BioZone Project has the ability to impact several areas including significantly and positively; the Biocontagion Biodefense of the United States inclusive of an Early Warning and Prepandemic Preparedness System, better mitigating environmental pollutants, protecting wildlife and game and the local and national revenues generated thereof, providing a new generation of diagnostic, medical management, and interventional equipment, and better protecting healthcare personnel and providers from contagious disease transmission.

All potential patients of ICUs, contagious disease patients, soldiers or field workers in any environment, wildlife that may have contagious diseases, or international travelers that need to

be isolated for assessment could all be positively impacted by BioZone technology. The military will have a rapid deployment system to treat patients subject to contamination, as will hospitals, outpatient clinics, wildlife agencies. Additionally, the BioZone Project aims to reduce healthcare expenditures by billions of dollars and through providing a comprehensive Biodefense Plan, and potentially save millions of lives.

The project's impact could extend to military personnel and combat zones, where the mobile and rapidly deployable comprehensive All-in-One Emergency and Critical Apparatus is capable of deployment anywhere on land, sea, air, or space inclusive of high-risk areas such as battlefields. The BioZone Emergency and Critical Apparatus could provide a valuable asset for protecting and treating military personnel and civilians from infectious agents and bioterrorism threats. Overall, the success of the BioZone Project could have a significant impact on public health, environmental conservation, and national security.

Cost and Time of Development

The initial cost for 'Phase One' of the BioZone Project is estimated to be \$10,000,000.00, with a milestones and deliverables plan spanning over a period of three years. Phase Two of the BioZone Project could be developed concurrently with Phase One with appropriate funding, and the market projection for both phases would in that case be expected to be five years from the onset of the funded project. However, it is important to note that these estimates are subject to change based on various factors such as the availability of funding and the timeline for regulatory approvals. Phase Two of the BioZone Project is estimated to be an additional \$10,000,000.00.

Phase One of the BioZone Project will develop the basic components required to be an operative apparatus. The BioZone Base Unit, the isolation enclosure cabinet, the subsystems necessary for operating the unit, and the BioZone Multipurpose Biosensor entail the entirety of the 10-million-dollar funding request. As mentioned, all of the remaining technologies and innovations of the BioZone System will require additional funding whereby the successful product realization of Phase One is expected to validate the potential of equity sharing the Phase Two complement technologies. Phase One funding therefore is crucial to the success of the entire project.

Project Timeline:

Phase 1: Research and Development (1 year)

- Conduct a thorough review of existing technologies and research on infectious diseases
- Identify key partners and stakeholders
- Develop technical specifications for the BioZone Field Unit, Roaming Unit, and POC Healthcare facility BioZone Unit

- Develop a conceptual design for the BioZone System

Phase 2: Prototyping and Testing (2 years)

- Develop and test prototypes of the BioZone Field Unit, Roaming Unit, and POC Healthcare facility BioZone Unit
- Conduct field testing to evaluate the performance of the prototypes
- Collect and analyze data to refine the design of the BioZone System

Phase 3: Manufacturing and Deployment (2 years)

- Establish a manufacturing process for the BioZone Field Unit, Roaming Unit, and POC Healthcare facility BioZone Unit
- Begin manufacturing and assembly of the BioZone System components
- Develop a training program for the use of the BioZone System
- Deploy the BioZone System in high-risk areas such as battlefields

Goals and Impact:

In the context of existing capabilities and approaches, the BioZone Project offers a unique solution to the challenges of biodefense, especially in terms of zoonotic transmission of diseases, which is expected to be the etiology of the next pandemic. The project's ability to rapidly detect known and or unknown pathogen elements through utilization of the BioZone Multipurpose Biosensor technology is innovative and unprecedented. Furthermore, the healthcare BioZone Unit's ability to decontaminate and sterilize the ambient atmosphere within waiting rooms and other areas could significantly reduce the spread of infectious diseases quickly and safely.

The deliverables associated with the proposed project include the development of BioZone Field Station Units, Roaming Units, and Healthcare POC Units that can detect, monitor, and treat infectious diseases in wildlife and human populations. The project's success may result in significant economic, environmental, and social benefits, including promoting the health and wellbeing of wildlife and game, protecting local, regional, and national recreational revenues, reducing healthcare expenditures, and potentially saving millions of lives, all the while providing a valid Biodefense program for the United States.

The BioZone team I plan on creating will deliver the solution for the problem of insufficient, expensive, and cumbersome contagious care or ICU facilities to quarantine, examine, treat, and mitigate the spread of contagious pathogens in Healthcare settings. The BioZone Unit Isolation Enclosure will positively impact government and private healthcare management by:

- Reducing the cost of contagious care in facilities by 70% or more, from approximately \$250k per ICU to under \$30k per Base Unit ICU or contagious care system.
- Eliminating facility remodeling for adding ICU or contagious care space that is disruptive, takes months to execute, and extremely expensive (see Fig. 4).
- Allow for rapid deployment of contagious care examination for field operations or for standard hospitals and treatment centers. Instead of weeks to months to implement contagious care, the BioZone Unit can be wheeled into place and set-up in less than 30 minutes.
- Provide centralized assessment, monitoring, and treatment using patient centric ventilation systems with AI analysis engines assessing the BioZone containment pressure apparatus. BioZone can serve as the hub for connecting all patient monitoring systems with data analysis capability to provide early warning for potential health issues.
- Commercialization plans for the BioZone Project may include partnering with government agencies and research institutions to conduct ongoing research and development to establish the efficacy of the biosensor technology. Furthermore, partnerships with product realization companies could help bring advanced technologies, such as the pulmonary drug delivery system and novel means for treating radiation exposure injuries, to market.

The ultimate goal is to have the BioZone Project implemented nationwide as a comprehensive biodefense strategy against natural or unnatural Biocontagion manifestations and provide a mainstay new generation standalone all-in-one Emergency and Critical Care Apparatus capable of rapid deployment anywhere on land, sea, air, or space.

- The current system for monitoring and controlling contagious and transmittable diseases in wildlife is inadequate, and the reliance on hunters to identify and report diseased animals is not effective. Chronic Wasting Disease (CWD) is an example of a disease that is constantly spreading, potentially becoming a zoonotic transmission source, and has no known curative treatments or vaccines. The spread of CWD has devastated hunting revenues in certain states, and there is concern about the potential for the disease to be spread to humans who consume the meat of infected animals.

It is imperative to develop technology to detect contagious pathogens in wildlife before they show signs of disease, to render diseases present in the environment harmless, and to identify, monitor, track, and eliminate diseased animals. The development of a system for detecting and integrating identified contagious pathogens with an Early Warning Biodefense System notification and activation system is also necessary.

Additionally, there is a need for an autonomous means of pathogen detection and rapid isolation of contagious patients without costly and time-consuming personal protective equipment. The COVID-19 pandemic has highlighted the importance of being prepared for such outbreaks and developing effective solutions to manage them.

Per the Center of Disease Control Fig. 3 Reveals guidance for needing Air Isolation Rooms

Evidence for airborne transmission	Fungi	Bacteria	Viruses
Numerous reports in health-care facilities	<i>Aspergillus</i> spp.+ <i>Mucorales</i> (<i>Rhizopus</i> spp.) ^{97, 115}	<i>Mycobacterium tuberculosis</i> +	Measles (rubeola) virus ¹⁶⁸⁻¹⁷⁰ Varicella-zoster virus ¹⁶²⁻¹⁶⁶
Occasional reports in health-care facilities (atypical)	<i>Acremonium</i> spp. ^{105, 206} <i>Fusarium</i> spp. ¹⁰² <i>Pseudoallescheria boydii</i> ¹⁰⁰ <i>Scedosporium</i> spp. ¹¹⁶ <i>Sporothrix cyanescens</i> ^{¶118}	<i>Acinetobacter</i> spp. ¹⁶¹ <i>Bacillus</i> spp. ^{¶160, 207} <i>Brucella</i> spp.* ²⁰⁸⁻²¹¹ <i>Staphylococcus aureus</i> ^{148, 156} Group A <i>Streptococcus</i> ¹⁵¹	Smallpox virus (variola)§ ^{188, 189} Influenza viruses ^{181, 182} Respiratory syncytial virus ¹⁸³ Adenoviruses ¹⁸⁴ Norwalk-like virus ¹⁸⁵
No reports in health-care facilities; known to be airborne outside.	<i>Coccidioides immitis</i> ¹²⁵ <i>Cryptococcus</i> spp. ¹²¹ <i>Histoplasma capsulatum</i> ¹²⁴	<i>Coxiella burnetii</i> (Q fever) ²¹²	Hantaviruses ^{193, 195} Lassa virus ²⁰⁵ Marburg virus ²⁰⁵ Ebola virus† ²⁰⁵ Crimean-Congo virus ²⁰⁵
Under investigation	<i>Pneumocystis carinii</i> ¹³¹	n/a	n/a

Fig. 3 CDC Guidance for Needing Air Isolation Rooms

The current state of the art for contagious care and ICUs involves either purpose-built rooms at a steep cost, mobile vans with limited space and high cost, or haphazard set-ups that are not reliable, easy to work with, or easy to replicate. Required ventilation systems for an ICU room in most Healthcare facilities now require remodeling and retrofitting to add contagious care or ICU space. This process is disruptive, takes months to execute, and extremely expensive costing approximately \$150k-\$250k/room.



Fig. 4 Remodeling existing rooms into contagion isolation rooms

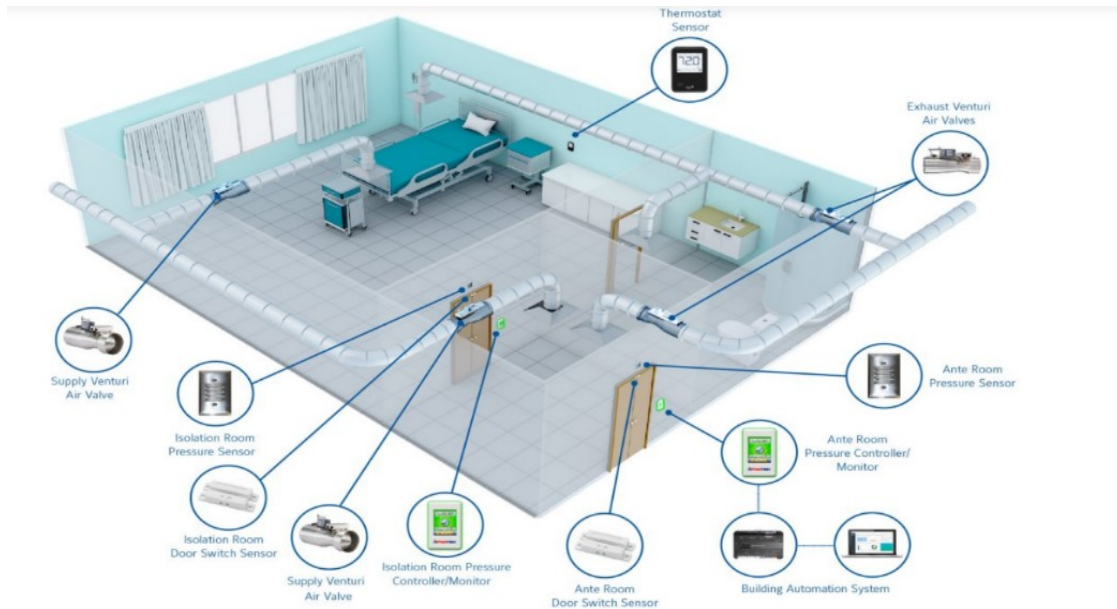

Diagram of a current ICU negative pressure room system

Technical Plan:

As described in the proposal, the BioZone Project faces several technical challenges, including:

- Providing an adequate territorial National Biodefense Surveillance and Monitoring means: The sheer measure of land area in square miles of natural wildlife habitats and the various terrain incumbrances make it challenging to provide an adequate territorial National Biodefense Surveillance and Monitoring means. The BioZone Project plans to address this hurdle by initially sectioning the United States into accessible and non-accessible land zones (the BioZone Map). These sectioned zones will be further partitioned into privately owned land versus public and governmental land. Once established, a decision will be made as to how large an area can be managed per BioZone Field Unit.
- Developing the BioZone Nutritional component(s): The BioZone Nutritional component(s) are a technical challenge, given the necessary research and development and subsequent regulatory hurdles and certifications. The BioZone Project plans to address these issues in cooperative partnering with appropriate government agencies and conducting ongoing research with institutions to establish the efficacy of the supplement objectives as outlined in previous sections. The project anticipates subcontractor assistance in the development of the BioZone product line. The essence of the nutritional supplementation is to effectively modify the gut microbiome in certain animals to thwart the absorption of specific molecules that have the potential to be deadly to the animal once absorbed.
- Finalizing the prototypes of the BioZone Field Stations and HCUs: The final prototypes of the BioZone Field Stations and HCUs will require considerable financial input. The project seeks funding assistance accordingly. Additionally, phase two advanced technologies planned for the HCU will require considerable research and development to realize the proposed utilities. The BioZone Project plans to achieve these objective technologies through research and development with world-renowned product realization companies

subcontractors and patent applications on several of the key BioZone System technologies, grant funding and potentially equity sharing participation.

To overcome these technical challenges, the BioZone Project will adopt the following strategies:

- Conducting extensive research and development: The project plans to partner with appropriate government agencies and conduct ongoing research with institutions to achieve the objectives, prototype development, and advanced technologies.
- Utilizing established subcontractors and partnerships: The BioZone Project plans to partner with established subcontractors and companies, such as the Plexus Organization in Wisconsin and Pivot International of Kansas City, Missouri, to achieve the project's technical goals.
- Implementing rigorous quality control measures: The project plans to implement rigorous quality control measures to ensure the accuracy and safety of its products and services.
- Utilizing appropriate funding sources: The BioZone Project seeks funding assistance from appropriate sources to ensure the necessary financial input required for the project's successful execution.

The project plans to establish appropriate measurable milestones at intermediate stages of the proposed research to demonstrate progress and a plan for achieving the milestones. The BioZone Project's technical plan demonstrates a deep understanding of the technical challenges and presents a credible plan to achieve the proposal's stated goal. The project also discusses mitigation of technical risk by adopting appropriate strategies to overcome potential problems.

Management Plan:

The BioZone Project team will be composed of experts from various fields, including medical professionals, wildlife and environmental experts, engineers, biochemists, product realization experts, and computer sciences experts. The team will be led by myself (Dr. Dennis Morris MD), being a physician and innovator with nearly 40 years of experience in emergency medicine and a project portfolio of nearly 100 novel technologies and innovations. I will also serve as the Principal Investigator (PI) for the project. The BioZone team will also include subcontractors and collaborating institutions such as the University of Texas at Austin's Engineering Department, Plexus Organization, and Pivot International. These organizations will provide technical expertise and support in the development of the BioZone Field Stations and HCUs.

I will develop the team with an organized hierarchy, with me overseeing the entire project and collaborating with experts in wildlife and environment, engineers, logistics, and medical professionals.

- The team will be divided into subgroups based on specific areas of expertise, such as development, research, and clinical trials. Each subgroup will have a designated leader responsible for overseeing the progress of the subgroup and ensuring that they meet the project's milestones and deliverables.
- The team will utilize a risk management approach, which includes identifying potential risks and developing plans to mitigate them.

- The team will also establish formal teaming agreements with subcontractors and collaborating institutions to ensure effective communication and coordination.
- The team will be responsible for overseeing the development of the BioZone System, ensuring that the project stays on track and within budget, and delivering a successful product that meets the objectives of the project.
- The project team will identify potential risks and develop risk management strategies to mitigate or avoid them.
- Risks could include delays in development and manufacturing, changes in project scope or requirements, unforeseen technical issues, and cost overruns.
- The team will expend effort based on the specific tasks assigned to them and the project's milestones and deliverables. The team's effort will be tracked and reported regularly to ensure that the project stays on schedule and within budget.

Fig. 5 represents an example GAANT Chart that may be utilized to follow completions of tasks.

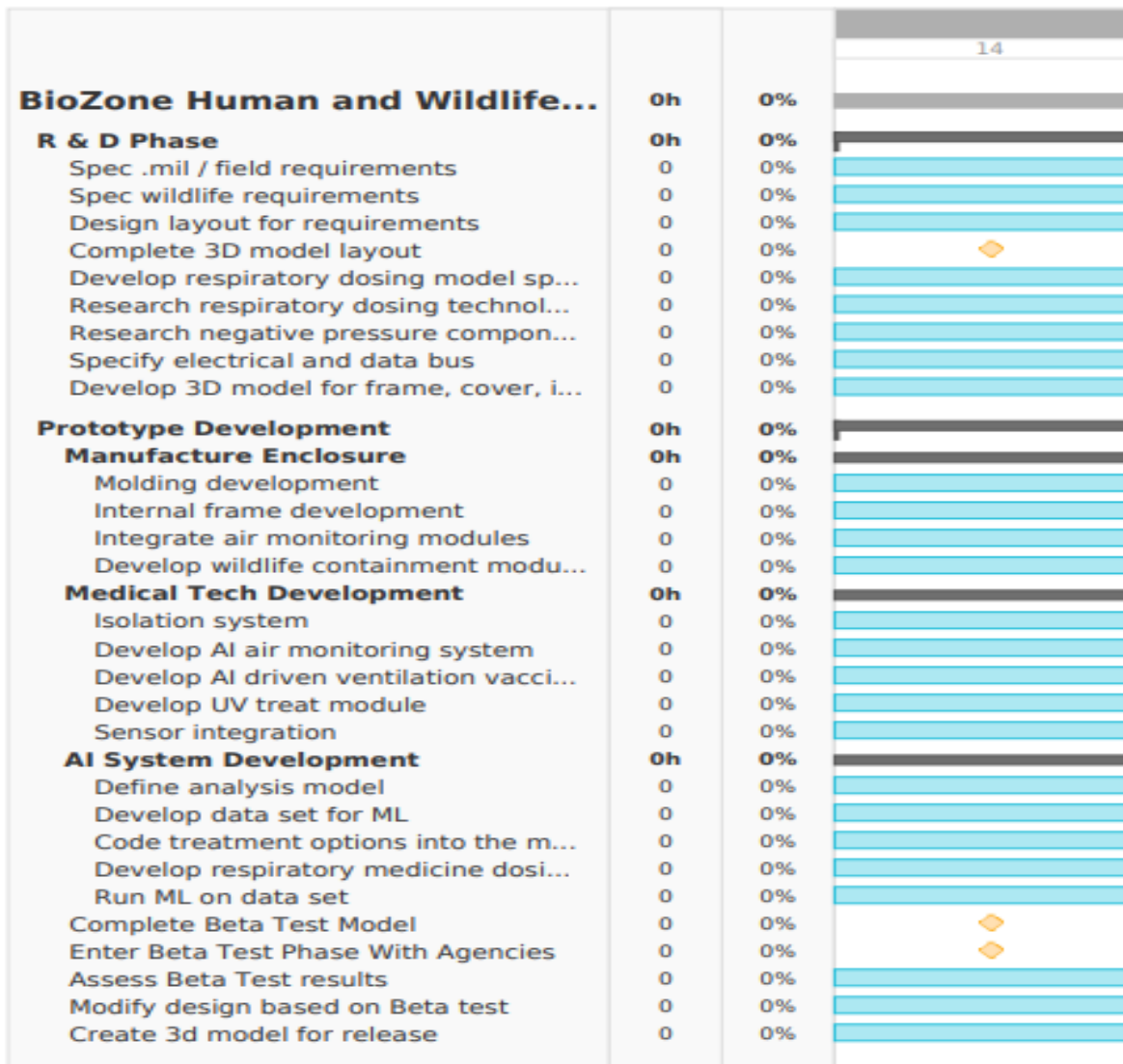

Fig. 5. GAANT Completion Chart

Statement of Work (SOW):

The BioZone Project's overarching goal is to provide a modeling construct that offers a foundation for incorporating forthcoming and newly derived associate technologies into the BioZone Project. In this way, continuous improvement will impact the overall success of the BioZone System. A modular configuration of the component BioZone technologies is preferred, which is cost-saving, compact, completely mobile, lightweight, and deployable anywhere on land, sea, air, or space.

It will be demonstrated that these advantages of the BioZone Units will be significantly advantageous by providing rapid deployment capabilities of an all-in-one standalone Emergency and Critical Care Unit in high-risk areas, or underserved regions. The BioZone System, in one aspect is designed to prevent, detect, forecast, and treat the emergence and spread of infectious diseases. This proposal offers an innovative and comprehensive solution that addresses healthcare challenges and concerns, making it an invaluable asset for any organization seeking to improve global health outcomes.

The BioZone modular and adaptable designs and configurations allow for a seamless and easily customizable platform capable of addressing a diverse range of project objectives. For instance, the initial Covid-19 scope of the BioZone System was further expanded to address the environmental, wildlife, and ecological aspects of the National Biodefense Strategy.

“The United States is under constant threat from foreign animal diseases such as highly pathogenic avian influenza, New World screwworm, cattle fever carried by cattle fever ticks, African swine fever, foot and mouth disease, Rift Valley fever, and Ebola hemorrhagic fever. Driving the emergence and impacts of these diseases are a number of factors including invasive species, the wildlife trade (both legal and illegal), land-use changes, and increased contact between humans, domestic animals, and wildlife.”

Source: <https://www.doi.gov/ocl/disease-and-wildlife-management>, **Testimony of Stephen Guertin, Deputy Director for Policy, U.S. Fish and Wildlife Service, Department of the Interior before the Senate Committee on Environment and Public Works regarding “Examining the Impacts of Disease on Wildlife Conservation and Management” October 16, 2019)**

A Point of Care (POC) integrated Healthcare Facility component was also developed and subsequently modified to provide solutions to a number of healthcare problems. Moreover, a BioZone Space Version was developed, addressing issues such as spacecraft impacts and high-energy cosmic radiation exposure.

As a complex matrix of advanced component technologies, the BioZone Project and System must be evaluated as a whole. It provides high-value solutions to numerous requests disseminated from governmental agencies. For example, the BioZone Project and System is a response to the 2022 National Biodefense Strategy & Implementation Plan, which calls for countering biological threats, enhancing pandemic preparedness, and achieving global health security. This framework organizes how the U.S. Government manages its activities to assess, prevent, prepare for, respond to, and recover from biological threats more effectively.

Additionally, the BioZone Project builds on a holistic 'One Health' approach that recognizes the interconnections among people, animals (domestic and wildlife), plants, and the environment. In

this way, the One Health approach interweaves the efforts needed to address the threats to all of these realms.

The BioZone Project also provides innovative solutions to local and state requests for addressing and preventing the spread of specific disease presentations. Currently, several wildlife populations, public recreational revenue, and human beings are endangered by such diseases with a potential for spillover zoonotic transmission. The BioZone Project aims to address these concerns with novel solutions that prevent and mitigate the spread of these diseases, thereby improving the health outcomes of both wildlife and human populations.

The National Biodefense Plan's strategy expands the U.S. Government's efforts to address the full range of future biological threats, including those of natural, accidental, and deliberate origin. It also incorporates both technological and policy needs revealed by the Covid-19 pandemic and provides an opportunity to build core values of equity and accountability into our efforts to protect the health and security of the American people. The plan's success relies on a culture of collaboration and experimentation to address novel and persistent threats in a way that ends rather than exacerbates existing inequities.

The BioZone Project recognizes the complexity of the interplay of problems and the need for a comprehensive and multifaceted approach to solve these problems. I believe that the BioZone Project and System has developed the mechanisms necessary for successful intervention. My intention is to provide a comprehensive set of strategic provisions, including novel technologies, countermeasures, and mitigants necessary to achieve the goals of the National Biodefense Strategy & Implementation Plan.

In general, the proposed work will provide the United States with a paradigm-shifting approach to integrating environmental, wildlife, ecological, military, and public health wellbeing. Using autonomous BioZone Field Units and BioZone Roaming Units, an Early Warning Biodefense System is delivered, capable of detecting and analyzing known and unknown harmful pathogens, contagions, and other biohazards.

The Field Units also provide a means for decontamination and sterilization of a specific BioZone Area radially peripheral to the Field Units, as well as a preventative means to isolate and prevent the spread of biocontagions. The acquired data is remotely transmitted to autonomous Central Control Stations for further dissemination and therein providing an overall coordinated communication network between the three BioZone Unit . Additionally, the Field Units provide for the identification and tracking of infection-transmitting vectors before they become physically detectable, enabling early therapeutic treatment.

In another general aspect, my proposed work provides a Point of Care (POC) Healthcare Facility Early Warning Biodefense Mechanism. The system detects known and unknown contagious pathogens, analyzes and compares them to pathogen libraries through AI-assisted software, and rapidly and adequately isolates patients from the public, staff, and healthcare professionals to prevent further transmission of the Biocontagion. The POC BioZone Unit decontaminates and sterilizes the Bio-Zone Area radially peripheral to the unit, provides a proprietary temporary isolation cabinet enclosure, and transports the isolated patient to other areas of the facility for conventional treatment and necessary interventional care. The BioZone POC Unit temporarily and comfortably houses the patient for as long as they remain a contagious threat to the public and staff and are discharged pursuant to protocol requirements and mandates.

Moreover, the expanded scope and modular construct of the Healthcare BioZone Unit may also provide a novel Pulmonary Drug Delivery System. This system can facilitate enhanced therapeutic delivery to pulmonary tissues, activate pharmaceutical drug carriers and modulators, mitigate regenerative and reparative pulmonary damage, prevent cytokine storm development, and offer novel treatment modalities for a vast number of inflammatory diseases. The remarkable versatility and efficacy of the Healthcare BioZone Unit's modular design make it an invaluable tool in improving global health outcomes and promoting public health and wellbeing. The BioZone Project and System provide a comprehensive and innovative solution to addressing the multifaceted and complex challenges of preventing, detecting, forecasting, and treating the emergence and spread of infectious diseases, thereby improving the health and wellbeing of communities across the United States and the world.

In addition to the advanced technologies discussed above, the BioZone System comprises a novel standalone all-in-one Emergency and Critical Care Apparatus that is mobile, lightweight, and compact, allowing for easy transport to any area on land, sea, air, or space. The apparatus includes improved airway management, an EKG with improved interpretive signal detection and analysis, and an improved vital sign determination means. Additionally, it offers more accurate oxygen saturation determinations, an increased survival rate for patients undergoing cardiac resuscitation, and the ability to detect acute cardiac events and developments prior to conventional equipment. The system also offers a means to better identify subtle ischemic events in patients, such as Van Negative Cerebral Hypoxic Events, and significantly reduce the time that healthcare providers document, enabling more direct patient care time availability. The BioZone System also features an innovation blockchain application network and participation means, as well as countermeasures and mitigants to surveil environmental and wildlife issues such as Prion diseases like Chronic Wasting Disease of deer and elk. The system can remove chemical pollutants like PFAs from land and water, affecting fish, wildlife, and human health and wellbeing.

In summary, the BioZone Initiative and Project proposes to provide an early warning biodefense system, an all-in-one emergency medicine and critical care evaluation and treatment apparatus, improved and safer means for healthcare providers to evaluate, manage, and treat serious contagious disease patient presentations, novel therapeutic treatment modalities, significant advances in medical device technologies, and a wildlife and environmental conservation program and platform. The initiative can save billions of dollars in United States healthcare expenditures and has the technological capacities to save millions of lives. This project introduces a novel 'non-lethal' hunting practice of animals, providing vital project data, animal tracking provisions, testing of the animal for identifiable diseases, harmless recreational opportunities for the public, and a broad spread means for clearing toxins and pollutants from our land and water systems.

The BioZone Initiative and Project represents a comprehensive and innovative solution to address the multifaceted and complex challenges of preventing, detecting, forecasting, and treating the emergence and spread of infectious diseases, promoting public health and wellbeing, and preserving environmental and wildlife health. The BioZone Project and System proposes an innovative and comprehensive approach to addressing the emergence and spread of infectious diseases that have significant health, economic, and social consequences. The project aims to provide a platform and ecosystem for serious contagious infections, seamlessly integrating environmental, ecological, and public health issues and well-being.

The project will address the prevention of, surveillance, detection, monitoring, forecasting, mitigating technologies, and treatments, encompassing all relevant components necessary to accomplish the goals and objectives of the project. The unique approach of integrating environmental issues, ecological issues, and public health issues into a single project system is unprecedented, with no other proposal in the World having addressed these issues with such an all-in-one solution platform.

The BioZone Project is comprehensive and technologically challenging and no one person would have the expertise, skills, and time to develop all the provisions. An expert team will need to be assembled accordingly. To date, I have developed nearly 2000 pages of technical research and development toward realizing the comprehensive BioZone System. The proposal submitted herein requests adequate funding for a BioZone team to be created and for the funding adequate for at least Phase One of the BioZone Project which will fully develop the BioZone Basic Unit inclusive of the isolation provision, develop the BioZone Multipurpose Biosensor, and develop the intricacies necessary to operate the unit.

Conclusion

The development of the BioZone System will provide the United States with the paradigm-shifting approach to the integral Biodefense of environmental, wildlife, ecological, military, and public health wellbeing. The project intends to provide a comprehensive set of strategic provisions inclusive of novel technologies, countermeasures, and mitigants necessary to achieve the goals of the National Biodefense Strategy & Implementation Plan and the objectives set forth.

By the year's end I will have fulfilled my 40-year commitment to helping the underserved population with compassionate and respectful Emergency and Critical Care therein saving countless lives. God willing, I will devote the next 15 years of my life to give back to society through innovation and goodwill. The BioZone Project and my decade of dedicated research and development has provided remarkable associated technologies that will help see our Healthcare Industry enter a new generation of advanced technologies. The BioZone Project offers me a wonderful beginning in the next chapter of my journey and I will continue the mission and see the project brought to fruition.

It would be my honor to somehow be affiliated with the Hale Fox Rock Foundation and any funding assistance you might be able to facilitate the BioZone Project mission with will be forever endeared. I thank you for your consideration and time that went into your determination herein.

Sincerest and kindest regards,

Dennis Morris MD

Dr. Dennis J. Morris, MD

Founder and CEO of Vertu Realities LLC. and the Godsend BioZone Project



